

FEATURES

- DC - 400 MHz
- 40 dB Isolation
- Auto Mode Cycle Between Upper for Two Radio
- Failsafe Mode
- Bit Port for Functionality Testing in Aircraft



MODEL NO.
DSWX9078

Antenna Selector 4-Port

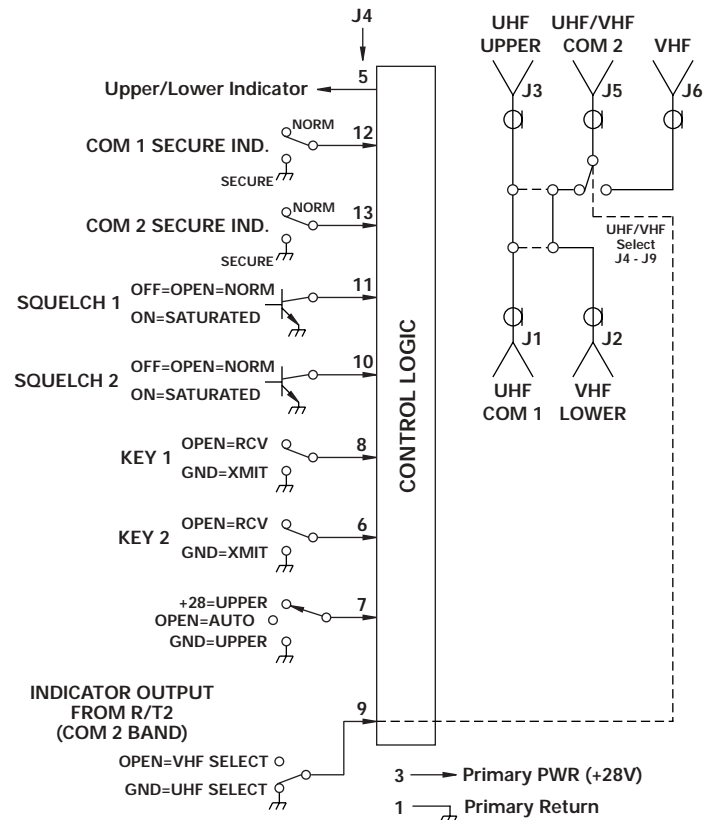
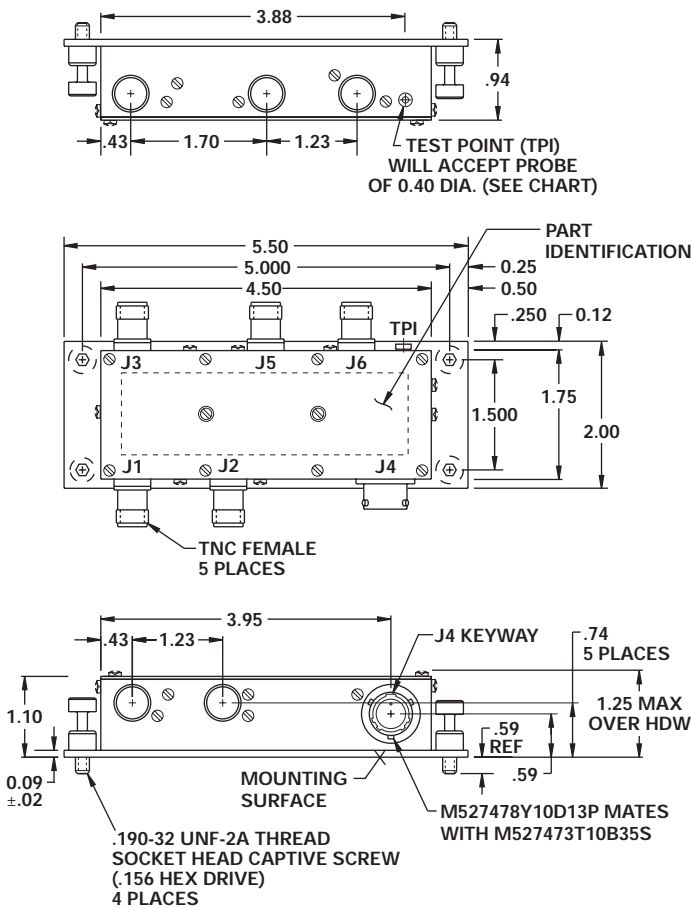

J4 CONNECTOR	
PIN	FUNCTION
1	Primary Power Return
2	Spare
3	Primary Power (+28V)
4	Spare
5	Upper/Lower Indicator
6	Com 2 Transmit Key
7	Mode Select
8	Com 1 Transmit Key
9	Com 2 Band Indicator (UHF/VHF Select)
10	Com 2 Squelch Input
11	Com 1 Squelch Input
12	Com 1 Secure Indicator
13	Com 2 Secure Indicator

Test Point (TPI) Chart			
Power On			
Mode	Com 1 to	Com 2 to	Test Point Voltage
A	Lower	VHF	1V
B	Lower	Upper	3V
C	Upper	VHF	5V
D	Upper	Lower	7V
Power Off			0V

GUARANTEED PERFORMANCE

Parameter	Min	Typ	Max	Units	Conditions
Operating Frequency	DC		500	MHz	
DC Current		210	350	mA	At +28 VDC Supply
Isolation	40	72		dB	
Insertion Loss			0.5	dB	30 - 400 MHz
			0.6	dB	400 - 500 MHz
			0.25	dB	J5 - J6 @ 30 MHz
VSWR		1.2/1	1.25/1		30 - 400 MHz
			1.35/1		400 - 500 MHz
Impedance		50		OHMS	
Switching Speed		2.6	5	mSec	
RF Power	Operate		100	W	Average
	No Damage		500	W	Peak
Operating Temperature	-54	+25	+71	°C	Intermittent @ +95°C