

SP2T

## FEATURES

- 10 - 2000 MHz
- TTL Driver
- Non-Reflective
- 14 Pin DIP
- See CDS0622 or 100C1558 for Connectorized Versions



# MODEL NO. DS0052

## PIN Diode SP2T

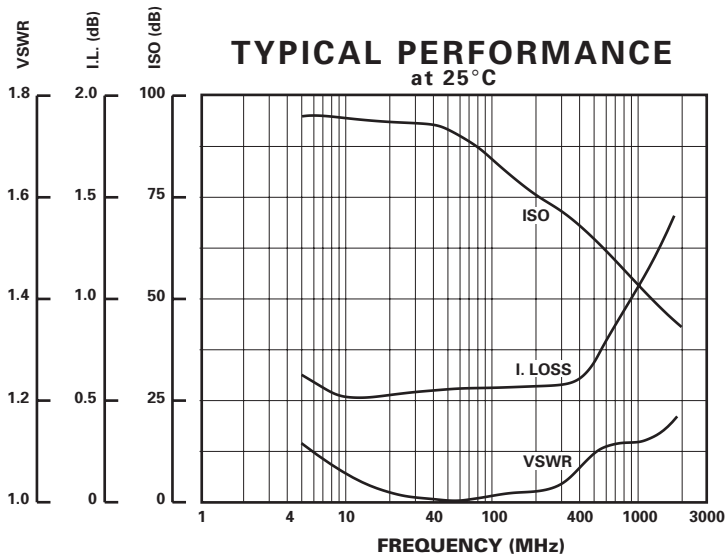
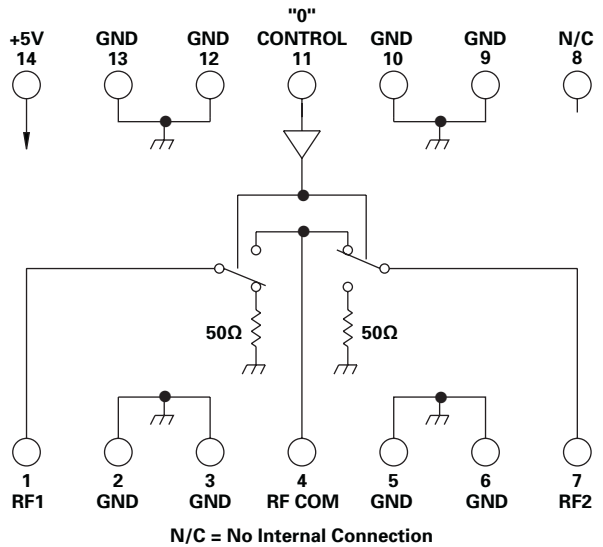
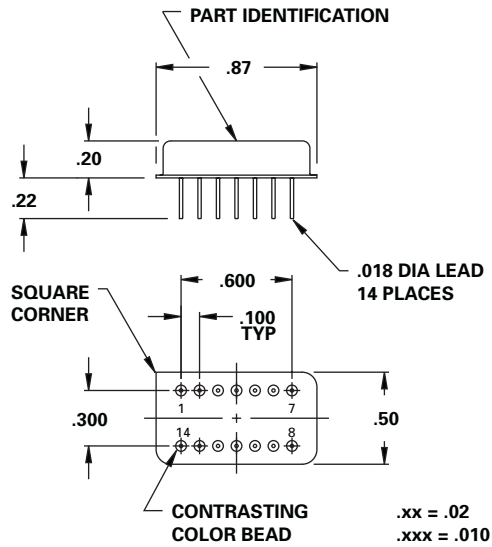

## GUARANTEED PERFORMANCE

Parameter	Min	Typ	Max	Units	Conditions
Operating Frequency	10		2000	MHz	
DC Current		15	25	mA	at +5 VDC Supply
Control Type		TTL			1 Line Logic "0" = RF COM to RF2 Logic "1" = RF COM to RF1
Control Current	High	1	20	μA	V <sub>IH</sub> = +2.7V
	Low	1	20	μA	V <sub>IL</sub> = +0.5V
Insertion Loss		0.6	0.8	dB	10 - 200 MHz
		0.9	1.2	dB	200 - 500 MHz
		1.0	1.6	dB	500 - 1000 MHz
		1.5	2.2	dB	1000 - 2000 MHz
Insertion Loss Flatness		±0.1	±0.2	dB	20 - 200 MHz
Isolation	70	82		dB	10 - 100 MHz
	50	62		dB	100 - 500 MHz
	40	50		dB	500 - 1000 MHz
	30	40		dB	1000 - 2000 MHz
VSWR	Thru	1.15/1	1.25/1		10 - 1000 MHz
	Termination	1.2/1	1.5/1		1000 - 2000 MHz
		1.1/1	1.3/1		10 - 1000 MHz
		1.3/1	1.5/1		1000 - 2000 MHz
Impedance		50		OHMS	
Switching Speed		0.4	1.0	μSEC	50% TTL to 90% / 10% RF
Transition (Rise/Fall) Time		0.1		μSEC	90% / 10% or 10% / 90% RF
Switching (Video) Transients		780		mV	Peak Value
Intercept Points	2nd	+72		dBm	70 MHz / 50 MHz
	3rd	+42		dBm	35 MHz / 50 MHz
RF Power	Operate	+12	+10	dBm	0.1 dB Compression
	No Damage		+30	dBm	
Operating Temperature	-55	+25	+125	°C	TA