

FEATURES

- 10 - 1000 MHz
- 1 mA, +5 VDC
- 1 dB LSB, 63 dB Range
- 34 nSec Switching Speed
- 15 nSec Transition Time
- TTL Control
- 24 Pin DIP
- See DA0786 for Surface Mount Version



MODEL NO.
DA0886

GaAs 6 Section Attenuator

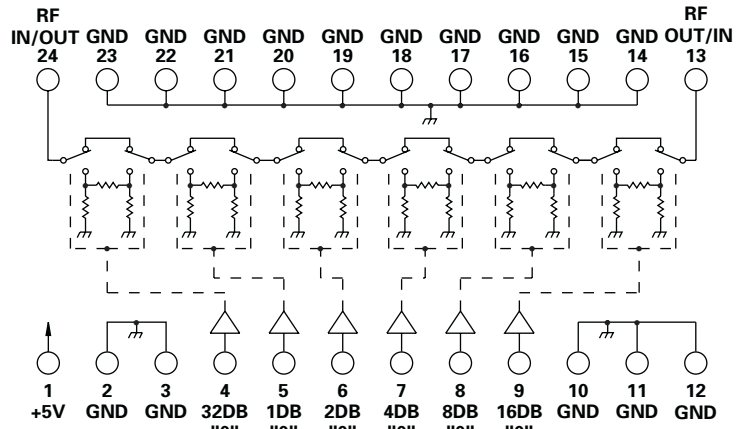
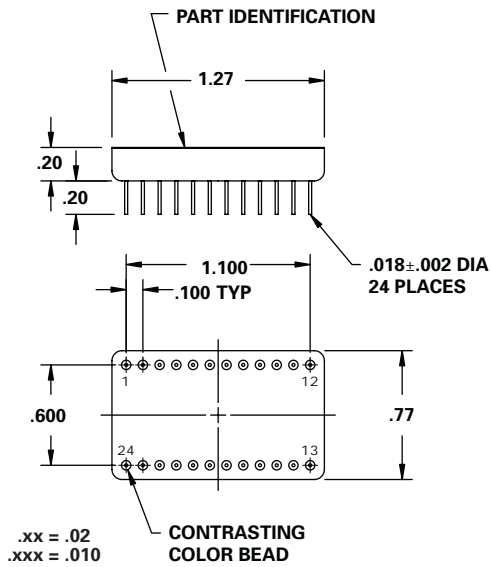

GUARANTEED PERFORMANCE

TYPICAL PERFORMANCE at 25°C

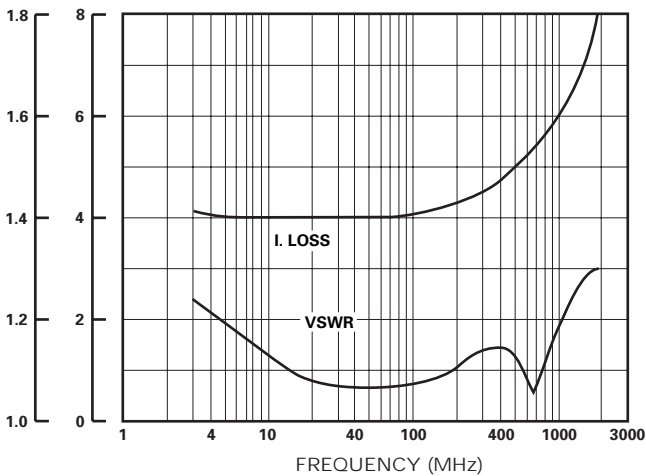

Parameter	Min	Typ	Max	Units	Conditions
Operating Frequency	10		1000	MHz	
DC Current		1	5	mA	At +5 VDC Supply
Control Type		TTL			6 Line Logic "0" = Thru Logic "1" = Attenuation
Control Current	High Low	0 0	±40 ±40	µA	V _{IH} = +3.0 V V _{IL} = +0.5 V
Insertion Loss		4.2 6.3	5.5 7.5	dB	10 - 100 MHz 100 - 1000 MHz
Attenuation	LSB Range Accuracy	0	1 63	dB	1, 2, 4, 8, 16, 32 ±(0.25 dB +2% of Atten. Setting in dB)
VSWR		1.2/1	1.4/1		
Impedance		50		OHMS	
Switching Speed		34	50	nSec	50% TTL to 90% / 10% RF
Transition (Rise/Fall) Time		15		nSec	90% / 10% or 10% / 90% RF
Switching (Video) Transients		280		mV	Peak Value
Intercept Points	2nd 3rd	+64 +44		dBm	70 MHz / 50 MHz 35 MHz / 50 MHz
RF Power	Operate No Damage	+12	+10 +27	dBm	0.1 dB Compression
Operating Temperature		-55	+25	+125	°C TA