

FEATURES

- 600 - 1400 MHz
- 34 mA, +5 VDC
- +44 dBm 3rd Order Intercept
- 2.8 dB Insertion Loss
- 1 dB LSB, 31 dB Range
- TTL Control
- Replaceable SMA Connectors



MODEL NO.
CDA0666

PIN Diode 5 Section Attenuator

5 BIT

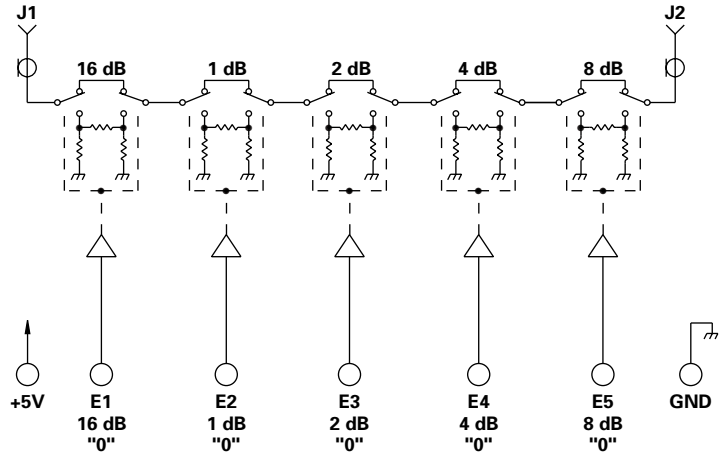
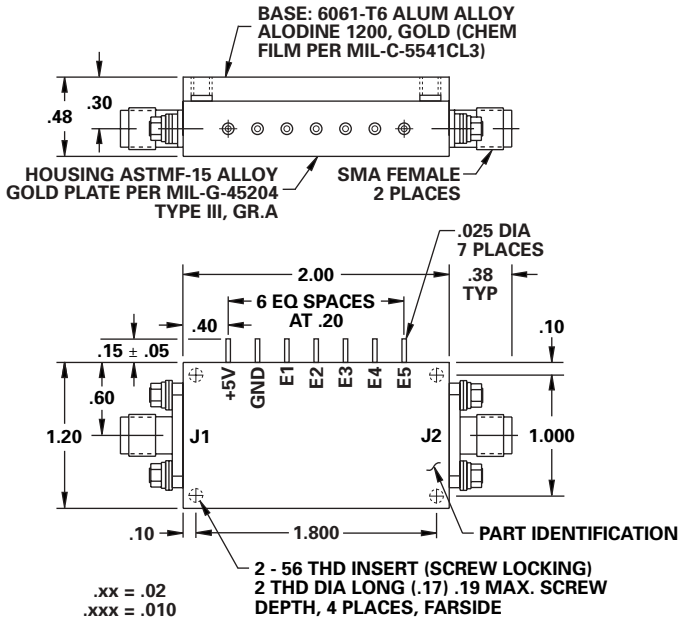

GUARANTEED PERFORMANCE

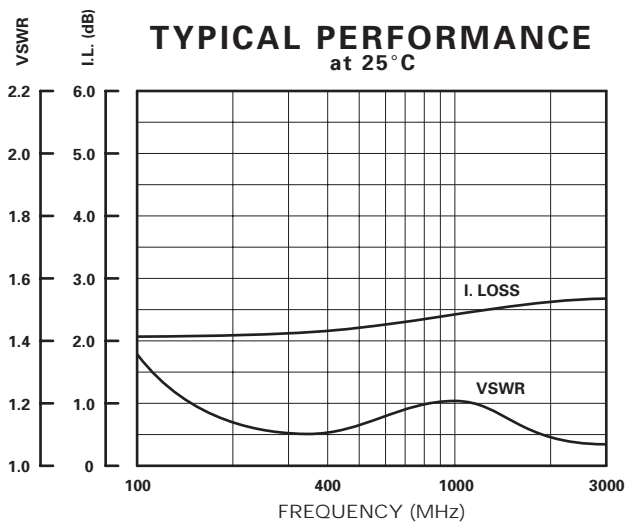

Parameter	Min	Typ	Max	Units	Conditions
Operating Frequency	600		1400	MHz	
DC Current		34	50	mA	At +5 VDC Supply
Control Type		TTL			5 Line Logic "0" = Thru Logic "1" = Attenuation
Control Current		0	±5	µA	V _{IH} = +2.7 V V _{IL} = +0.5 V
		0	±5	µA	
Insertion Loss		2.5	4.5	dB	
Attenuation		1	31	dB	1, 2, 4, 8, 16 ± (0.25 dB +2% of Atten. Setting in dB)
		0		dB	
VSWR		1.2/1	1.7/1		
Impedance		50		OHMS	
Switching Speed		0.2	1	µSec	50% TTL to 90% / 10% RF
Transition (Rise/Fall) Time		0.15		µSec	90% / 10% or 10% / 90% RF
Switching (Video) Transients		340		mV	Peak Value
Intercept Points		+60	+75	dBm	300 MHz / 720 MHz
		+30	+44	dBm	850 MHz / 700 MHz
RF Power		+23	+20	dBm	0.1 dB Compression
			+27	dBm	
Operating Temperature	-55	+25	+125	°C	TA